

CO₂ MOBILE FIRE EXTINGUISHER
MODEL-NTC 10X

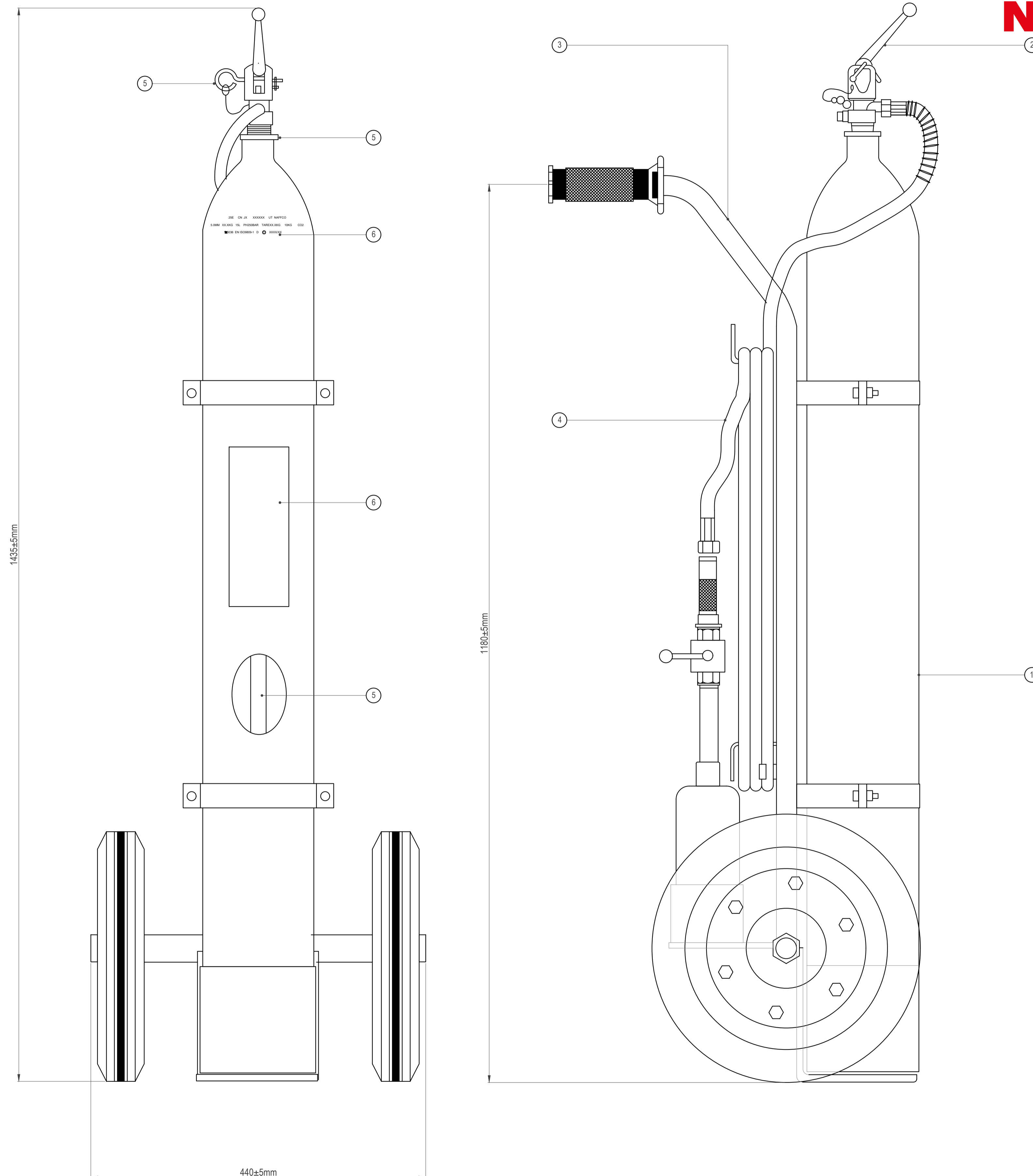

NOTES :-

1. ALL DIMENSIONS ARE IN mm. UNLESS OTHERWISE SPECIFIED

BILL OF MATERIALS

ITEM NO.	DESCRIPTION	MATERIAL	QTY.
1	CYLINDER	DIN 2448-1629 ST-52.0	1
2	HEAD VALVE	BRASS, CHROME PLATED	1
3	TROLLEY FRAME ASSEMBLY	SEAMLESS PIPE, SCH. 40	1
4	DISCHARGE HOSE/HORN ASSEMBLY	HIGH PRESSURE METAL BRAIDED HOSE	1
5	COMPONENTS & ACCESSORIES	-	-
6	MARKING & SCREEN PRINTING	-	-

SPECIFICATIONS

Model	NTC 10X
EXTINGUISHER CAPACITY	10kg
FIRE RATING	70B
WORKING PRESSURE	55-60BAR@25°C
MAXIMUM OPERATING PRESSURE	174BAR @60°C
TEST PRESSURE	250BAR
UNIT HEIGHT	1435MM
UNIT WIDTH	440MM
UNIT WEIGHT	52kg
RANGE OF DISCHARGE	6-8m
DURATION OF DISCHARGE	19-21 SEC.
OPERATING TEMPERATURE	-20° C to +60° C
PROPELLANT	SELF
HOSE SIZE & LENGTH	BORE 3/8" x 5m
CYLINDER MATERIAL	CARBON STEEL