

**100 LTR. FOAM MOBILE FIRE EXTINGUISHER -  
MODEL: NTFC 100X**

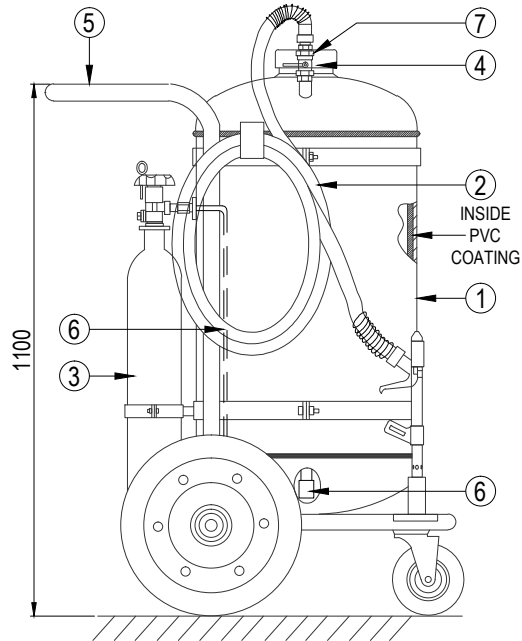
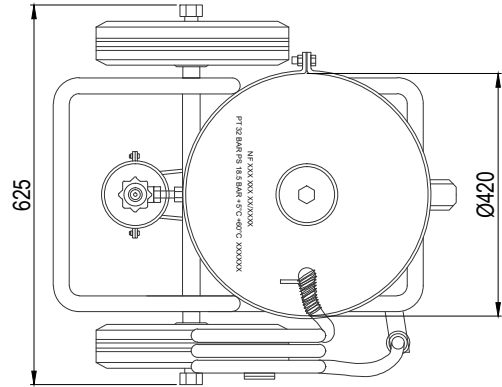

**NOTES :-**

1. ALL DIMENSIONS ARE IN mm. UNLESS OTHERWISE SPECIFIED
2. GENERAL TOLERANCE  $\pm 5$ mm.

**BILL OF MATERIAL**

ITEM No.	DESCRIPTION	MATERIAL	QTY.
1	CYLINDER	EN10025-2 S275 JR	1
2	DISCHARGE HOSE ASSEMBLY	STAINLESS STEEL	1
3	CO2 CARTRIDGE	CARBON STEEL	1
4	NECK RING & CAP	STAINLESS STEEL	1
5	TROLLEY ASSEMBLY	MILD STEEL FABRICATED	1
6	DIP TUBE & PRESSURIZING PIPE	STAINLESS STEEL	1
7	$\frac{3}{4}$ " BALL VALVE	BRASS, CHROME PLATED	1

MANUFACTURING STANDARD : BSEN 1866-1 : 2007 & BSEN 1866-2 :2014

**CARTRIDGE DETAILS:-**

CAPACITY	2.25 Kg.
GAS FILLED	1.5 Kg.
TEST PRESSURE	250 BAR
TARE WT.	6.20 Kg.
TOTAL WT.	7.70 Kg.

**SPECIFICATION:-**

MODEL	NTFC 100X
EXTINGUISHER CAPACITY	100 Ltr.
FIRE RATING	IVB
PROPELLANT	CO <sub>2</sub>
WORKING PRESSURE	14 BAR
TEST PRESSURE	32 BAR
MAX. W. PRESSURE	18.5 BAR
TOTAL WEIGHT	189 Kg.
RANGE OF DISCHARGE	8-10 Mtr.
DURATION OF DISCHARGE	110-120 Sec.
HOSE LENGTH	16 mm X 7m.
OPERATING TEMPERATURE	+5°C TO +60°C
CYLINDER MATERIAL	HOT ROLLED STEEL PLATE