

**2L. WET CHEMICAL FIRE EXTINGUISHER-
MODEL:NKE 2**

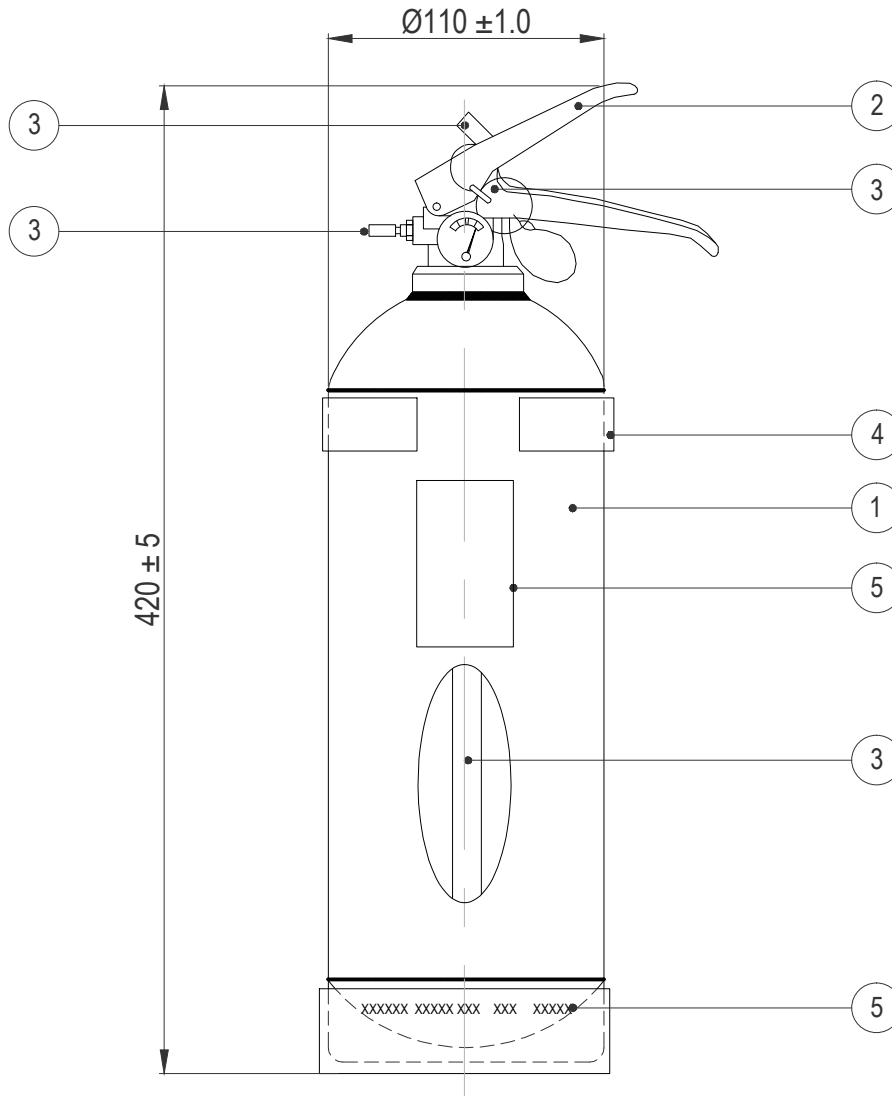

NOTES :-

1. ALL DIMENSIONS ARE IN mm. UNLESS OTHERWISE SPECIFIED

BILL OF MATERIALS

ITEM NO.	DESCRIPTION	MATERIAL	QTY.
1	CYLINDER	-	1
2	CONTROL VALVE	BRASS CHROME PLATED	1
3	COMPONENTS AND ACCESSORIES	-	1
4	BRACKET	PVC	1
5	MARKING & SCREEN PRINTING	-	1

SPECIFICATIONS

MODEL	NKE 2
EXTINGUISHER CAPACITY	2L
PROPELLANT	95% NITROGEN + 5% HELIUM
FIRE RATING	5F
WORKING PRESSURE	10 BAR
MAX. OP. PRESSURE	11.5 BAR @ 60°C
TEST PRESSURE	30BAR
TOTAL WEIGHT	4.4kg
RANGE OF DISCHARGE	1Mtr.
HOSE LENGTH WITH NOZZLE	N/A
DURATION OF DISCHARGE	40-45 Sec.
OPERATING TEMPERATURE	+5°C TO +60°C
CYLINDER MATERIAL	CRCA STEEL SHEET
HEIGHT	420mm.
DIAMETER	110mm.