

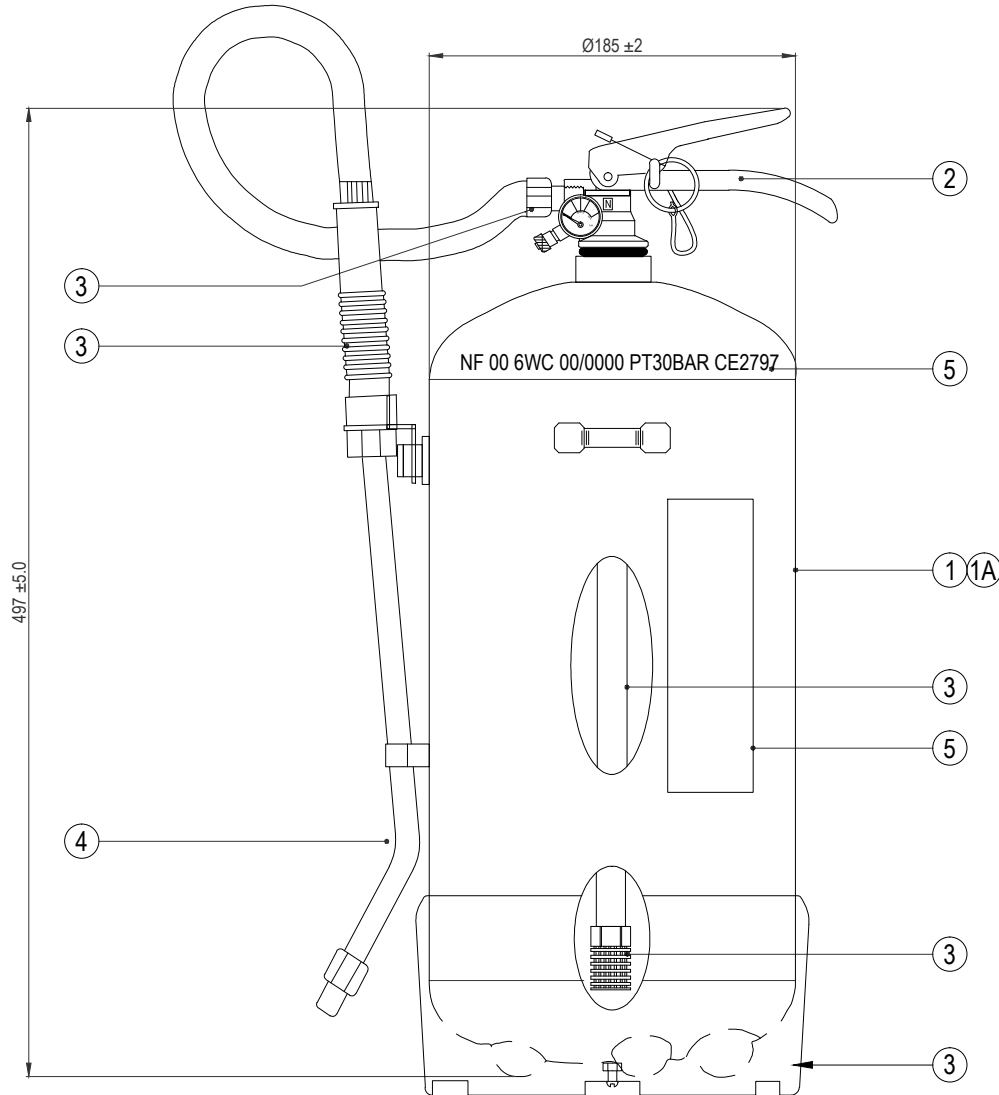

**6L. WET CHEMICAL FIRE EXTINGUISHER-
MODEL:NKE 6**



NOTES :-

1. ALL DIMENSIONS ARE IN mm. UNLESS OTHERWISE SPECIFIED

BILL OF MATERIALS

ITEM NO.	DESCRIPTION	MATERIAL	QTY.
1	CYLINDER	COLD ROLLED STEEL SHEET	1
1A	CYLINDER SUB ASSEMBLY	COLD ROLLED STEEL SHEET	1
2	CONTROL VALVE	BRASS, NICKEL PLATED	1
3	ACCESSORIES & COMPONENTS	-	1
4	APPLICATOR ASSEMBLY DETAIL	-	1
5	MARKING & SCREEN PRINTING	-	1

SPECIFICATIONS

MODEL	NKE 6
EXTINGUISHER CAPACITY	6L
PROPELLANT	95% NITROGEN + 5% HELIUM
FIRE RATING	13A 75F
WORKING PRESSURE	10 BAR
MAX. OP. PRESSURE	11.5 BAR @ 60°C
TEST PRESSURE	30BAR
TOTAL WEIGHT	12.5kg
RANGE OF DISCHARGE	1Mtr.
HOSE LENGTH WITH NOZZLE	810mm
DURATION OF DISCHARGE	50-55 Sec.
OPERATING TEMPERATURE	+5°C TO +60°C
CYLINDER MATERIAL	CRCA STEEL SHEET
HEIGHT	505mm.
DIAMETER	185mm.