

**05L. DCP FIRE EXTINGUISHER -  
MODEL: NP 05L**

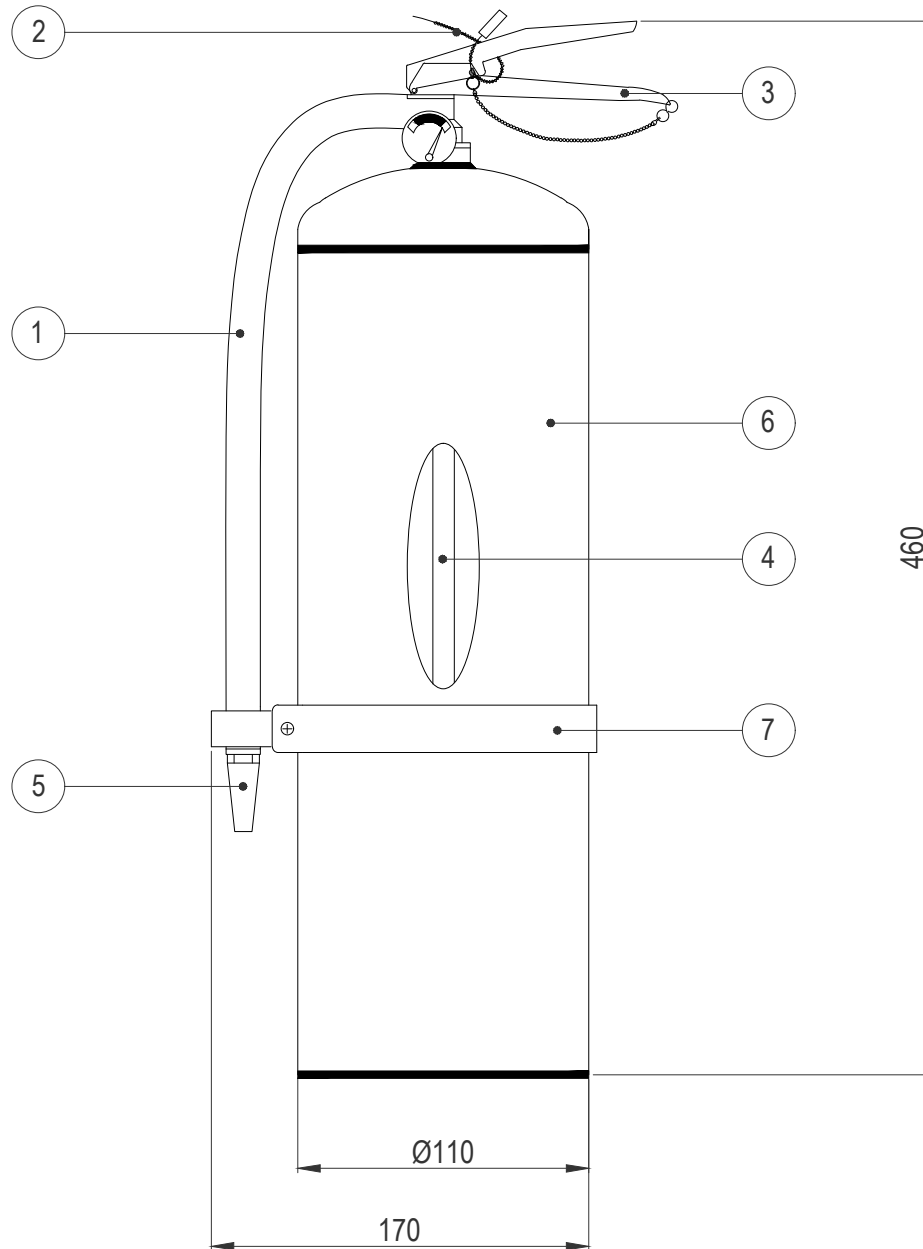

**NOTES :-**

- ALL DIMENSIONS ARE IN mm. UNLESS OTHERWISE SPECIFIED

**BILL OF MATERIALS**

ITEM NO.	DESCRIPTION	MATERIAL	QTY.
1	HOSE	HIGH PRESSURE HEAVY DUTY	1
2	SAFETY BELT	PLASTIC	1
3	SQUEEZE GRIP VALVE	ALUMINIUM	1
4	DIP TUBE	ALUMINIUM	1
5	DISCHARGE NOZZLE	PLASTIC INJECTION MOLDED	1
6	CYLINDER	ALUMINIUM	1
7	BELT FOR HOSE ASSY	GALVANIZED IRON	1

**SPECIFICATION:-**

MODEL NO.	NP 05L
EXTG.AGENT	ABC DRY CHEMICAL POWDER
CYLINDER CAPACITY	5 LB. (2.27KG)
UL FIRE RATING	3-A:30-B:C
CYLINDER MATERIAL	STEEL SHEET
OVER ALL HEIGHT OF THE CYLINDER	+10.0 -0.0 460 mm
OUTSIDE DIAMETER	110 MM
UNIT WIDTH	170MM
SHIP WEIGHT	4.44 KG
DISCHARGE TIME	14 SEC
RANGE (FT/M)	14 / 4.3
WORKING PRESSURE	195 psi
MAX. OPERATING TEMPERATURE	-40° C ~ +49° C