

**20L. DCP FIRE EXTINGUISHER -  
MODEL: NP 20L**

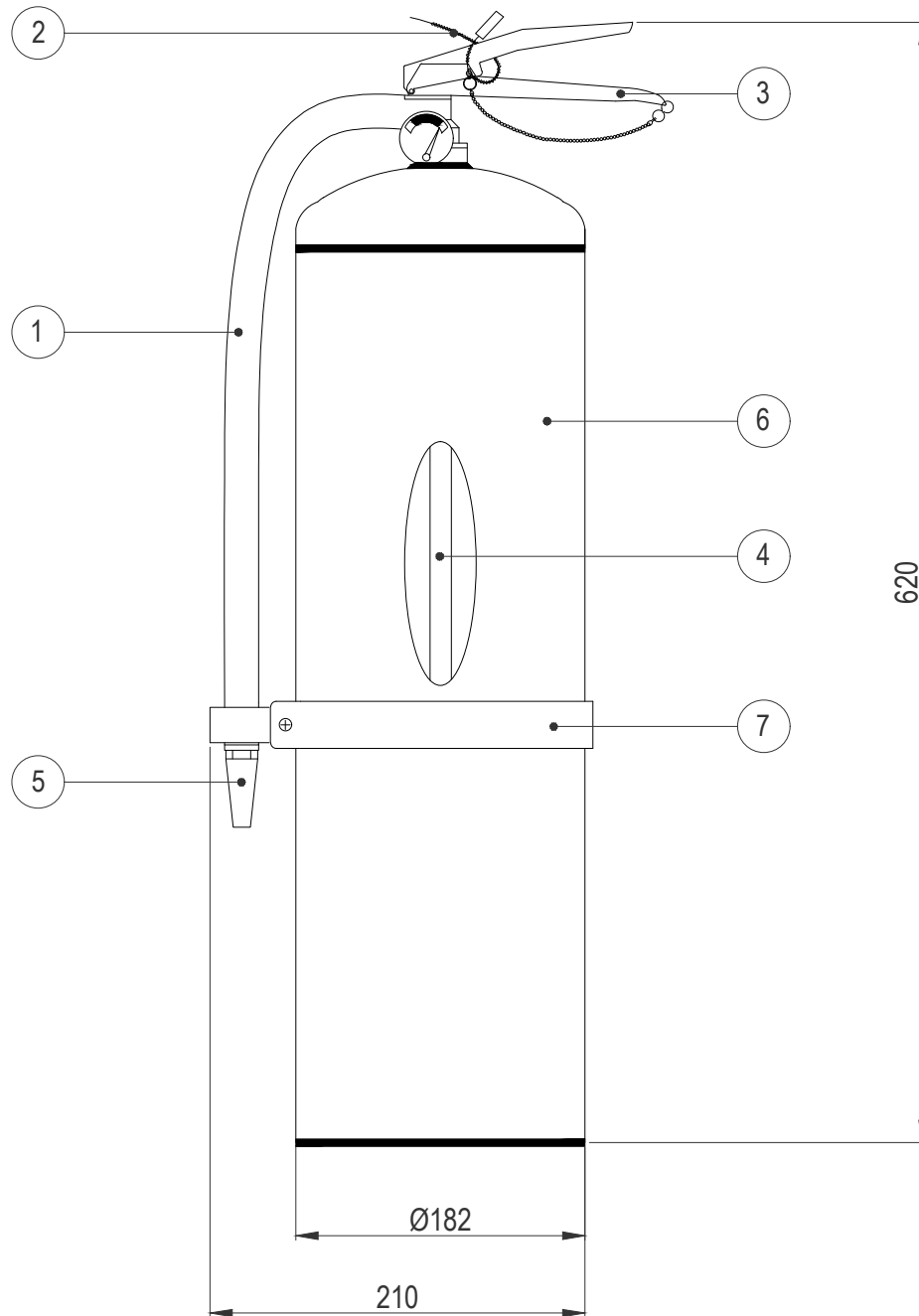

**NOTES :-**

1. ALL DIMENSIONS ARE IN mm. UNLESS OTHERWISE SPECIFIED

**BILL OF MATERIALS**

ITEM NO.	DESCRIPTION	MATERIAL	QTY.
1	HOSE	HIGH PRESSURE HEAVY DUTY	1
2	SAFETY BELT	PLASTIC	1
3	SQUEEZE GRIP VALVE	ALUMINIUM	1
4	DIP TUBE	ALUMINIUM	1
5	DISCHARGE NOZZLE	PLASTIC INJECTION MOLDED	1
6	CYLINDER	ALUMINIUM	1
7	BELT FOR HOSE ASSY	GALVANIZED IRON	1

**SPECIFICATION:-**

MODEL NO.	NP 20L
EXTG.AGENT	ABC DRY CHEMICAL POWDER
CYLINDER CAPACITY	10 LB. (4.54KG)
UL FIRE RATING	4-A:60-B:C
CYLINDER MATERIAL	STEEL SHEET
OVER ALL HEIGHT OF THE CYLINDER	+10.0 -0.0 620 mm
OUTSIDE DIAMETER	182 MM
UNIT WIDTH	210MM
SHIP WEIGHT	13.86 KG
DISCHARGE TIME	30 SEC
RANGE (FT/M)	22 / 6.7
WORKING PRESSURE	195 psi
MAX. OPERATING TEMPERATURE	-40° C ~ +49° C