

**OBLIQUE LANDING VALVE, THREADED INLET,
MODEL: NDRT 096T**



NOTES:-

1. VALVE SHALL BE PAINTED WITH TWO COATS OF PO RED PAINT.
2. RATED WORKING PRESSURE: 175 PSI.
3. ALL DIMENSIONS ARE IN MM.
4. VALVE SEAT TIGHTNESS TEST AT 16 KG/CM² (225 PSI) FOR 5 MINUTES SHALL NOT SHOW ANY SIGNS OF LEAKAGE.
5. BODY TEST AT 50 KG/CM² FOR 5 MINUTES SHALL NOT SHOW ANY SIGNS OF LEAKAGE.

BILL OF MATERIALS

ITEM NO.	DESCRIPTION	MATERIAL
1	BODY	GUNMETAL
2	BONNET	GUNMETAL
3	SPINDLE	BRASS
4	HAND WHEEL	CAST IRON
5	O RING FOR GLAND	SYNTHETIC RUBBER
6	HEX. NUT	M.S. GALVANIZED
7	SEAT VALVE NUT	BRASS
8	SEAT WASHER	SYNTHETIC RUBBER
9	SEAT VALVE	FORGED BRASS
10	SEAT WASHER	BRASS
11	CHECK NUT	BRASS
12	GLAND NUT	BRASS
13	BONNET WASHER	SYNTHETIC RUBBER
14	HAND WHEEL WASHER	M.S. GALVANIZED
15	COTTER PIN	BRASS
16	OUTLET WASHER	SYNTHETIC RUBBER
17	SPRING	PH. BRONZE
18	CAM TOOTH	FORGED BRASS
19	UPPER PART OF LUG	FORGED BRASS
20	HEX. NUT (CAM TOOTH)	SS 304

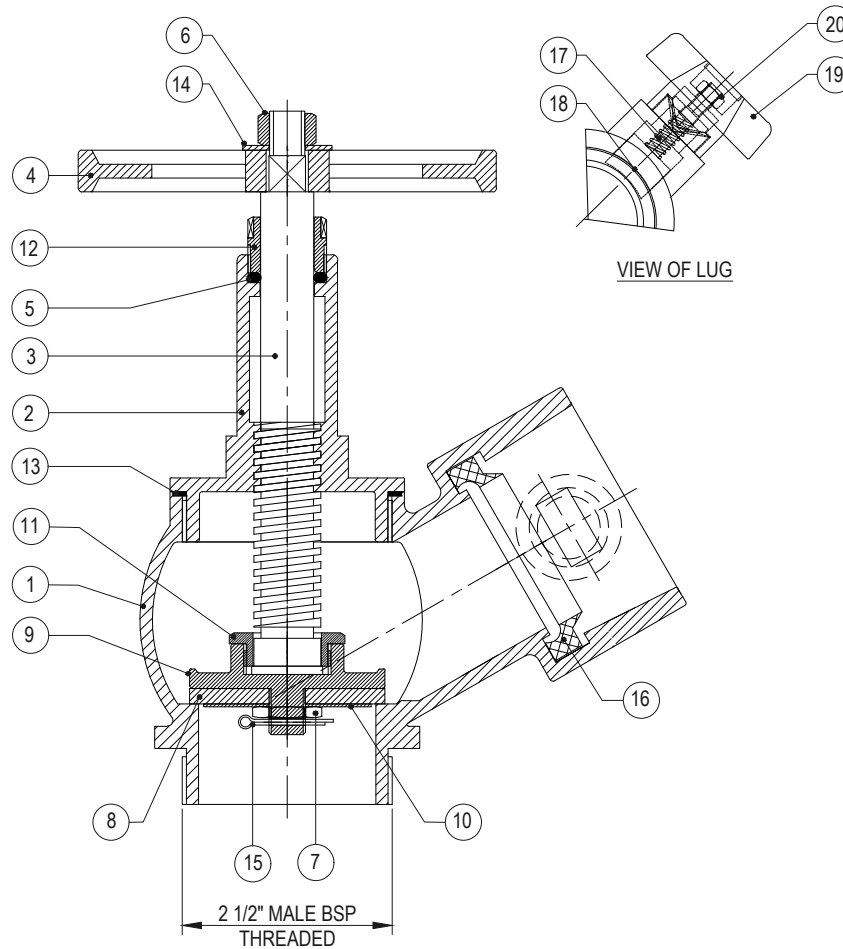

SPECIFICATION:-

MODEL	NDRT 096
VALVE TYPE	OBLIQUE, THREADED INLET
INLET TYPE	2 1/2" MALE BSP
OUTLET TYPE	2 1/2" FEMALE INSTANTANEOUS TO BS336
PRESSURE RATING	7 KG/CM ²
NOMINAL SIZE	DN 2 1/2"
WORKING PRESSURE	232 PSI
TEST PRESSURE	50 KG /CM ² (BODY TEST)
WATER FLOW RATE	1100 LPM @ 7KG/CM ²