

Glazed Partitions



**FIRE
INTEGRITY
UP TO
120min.**

This system has been designed and certified to provide maximum glazed areas with the minimum profile view and for achieving the maximum wall height. This system guarantees a comprehensive fire performance under the most severe fire conditions and provide multiple design possibilities. Available in galvanized steel powder coated finish. This system can be combined with any door system belonging to the NAFFCO Steel fire range. Tested and certified for E (Integrity), EW (Integrity & radiation) classification and up to 120 minutes of fire resistance, and according to European standard EN 1364-1.

Features and Benefits

- Fire protection
- Smoke protection
- Burglary-resistance
- Bullet resistance
- Thermal break
- Explosion inhibition
- Minimal face widths
- Without thermal break
- Great acoustic performance
- Interior & exterior use
- Multiple finishes.
- Largest glass area tested and certified

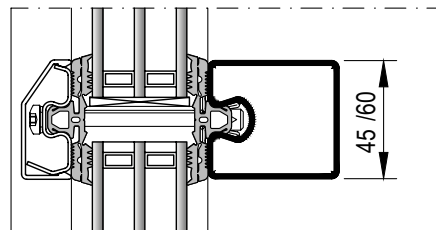
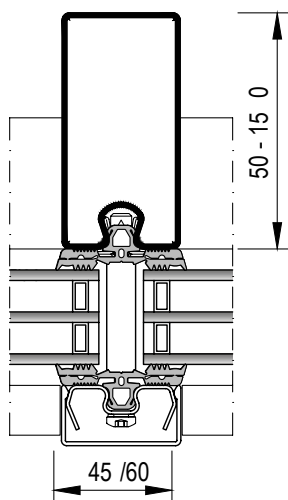
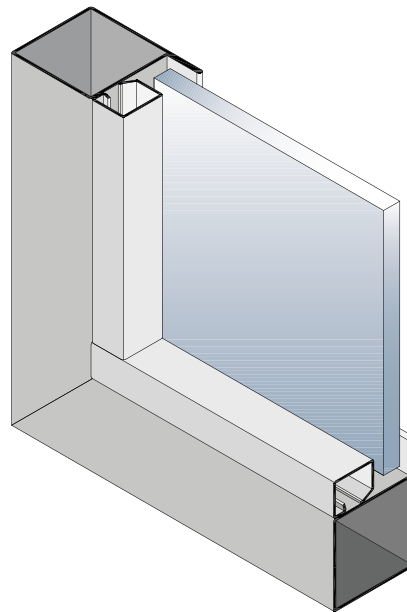

Technical Data

	Description	Result	Standard
Material options	Zinc magnesium (ZM) coated steel		
	Stainless Steel grade 304 and 316 (brush finish grain 220-240)		
	Available profile depth: 50 and 60mm		
Fire resistant options	Fixed partitions	E30 to E120 EW30 to EW120	EN 1364-1
Fire code compliance	European and North American Standards NFPA 101 and NFPA 80		
Tested design variants*	Smoke resistant doors	Sa, S ₂₀₀	EN 1634-3
Fittings	Fire resistant doors and screens		
	Hinges		
	Door closer		
	Door closers complete with in house cycling testing		
	Latch locks, lever handles, Self-closing flush bolts		
	Roller latches (for unlatched doors)		
System properties	Compatible with access control devices		
	Extremely slender visible section widths and depth		
	Can be powder coated or wet paint coated (to be checked with local applicator)		
	Large glass panels available for fire rated systems		
	Large door sizes available for fire rated systems		
	Extremely economical manufacturing without special equipment		
	Robust system, resistant to damage		
	Sound insulation (hinged doors, depth 50 mm)	Up to 42 dB	EN ISO 140-3
	Sound insulation (fixed screens, depth 50 mm)	Up to 46 dB	EN ISO 140-3
	Sound insulation (hinged doors, depth 60 mm)	Up to 45 dB	EN ISO 140-3
Sound insulation (fixed screens, depth 60 mm)	Up to 48 dB	EN ISO 140-3	