

## ► NFDAX / BX - Axial Box Fan

Axial box fans can be used in hard-to-install situations with its multiple connection point body. Default fan has an on-off switch and inbuilt sound attenuator.



MOTOR INSULATION CLASS	F CLASS
MOTOR PROTECTION CLASS	IP 55
MOTOR EFFICIENCY CLASS	IE2-IE3
MOTOR ENCLOSURE TYPE	TEFC
MOTOR BRAND	GAMAK-VOLT-WATT
BODY MATERIAL	GALVANIZED SHEET METAL
BODY COATING	NONE
IMPELLER MATERIAL	ALUMINIUM
DUTY CYCLE	IEC Duty Cycle-S1
WORKING TEMPERATURE	-20 - +50 °C
STANDARDS	IEC-60335-2-80, ISO 1940-1



MODEL	VOLTAGE (V)	FREQUENCY (Hz)	POWER (kW)	REVOLUTION (rpm)	FLOW RATE (m <sup>3</sup> /h)	NOISE LEVEL (dB(A))
NFDAX/BX 400-5-25	380	50	0,37	1.450	2.895	66
NFDAX/BX 450-5-25	380	50	0,55	1.456	4.180	69
NFDAX/BX 500-5-25	380	50	0,55	1.453	5.845	72
NFDAX/BX 560-5-25	380	50	0,75	1.466	8.150	75
NFDAX/BX 630-5-30	380	50	1,10	1.465	13.480	80
NFDAX/BX 710-5-30	380	50	1,50	1.472	19.210	83
NFDAX/BX 800-5-30	380	50	2,20	1.459	25.560	85
NFDAX/BX 800-5-35	380	50	3,00	1.463	30.940	89
NFDAX/BX 900-5-35	380	50	4,00	1.471	39.250	90
NFDAX/BX 900-5-40	380	50	5,50	1.472	44.635	93
NFDAX/BX 1000-5-40	380	50	7,50	1.478	54.570	94
NFDAX/BX 900-8-40	380	50	11,00	1.454	46.200	94
NFDAX/BX 1000-8-40	380	50	15,00	1.456	62.250	97
NFDAX/BX 1000-8-45	380	50	18,50	1.458	69.070	99
NFDAX/BX 1120-8-40	380	50	22,00	1.471	86.620	100
NFDAX/BX 1120-8-45	380	50	30,00	1.474	95.270	102

Values are for 0 Pa.

## ACCESSORIES



GRILL
MODEL
400
450
500
560
630
710
800
900
1000
1120

RUBBER PAD
MODEL
400
450
500
560
630
710
800
900
1000
1120

SPRING
MODEL
400
450
500
560
630
710
800
900
1000
1120

PANEL
MODEL
5,5 kW
7,5 kW
11,0 kW
15,0 kW
18,5 kW
22,0 kW
30,0 kW

## OTHER OPTIONS

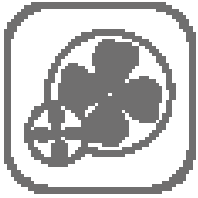

Custom Production For Any Flowrate and Pressure



System Automation

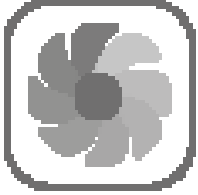

5, 8, 12 and 16 Blades Options

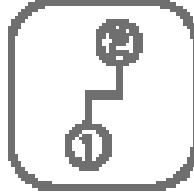

Two Speed Motor Option



Aluminium or Plastic Blades



Smoke Exhaust Motor

## DRAWING

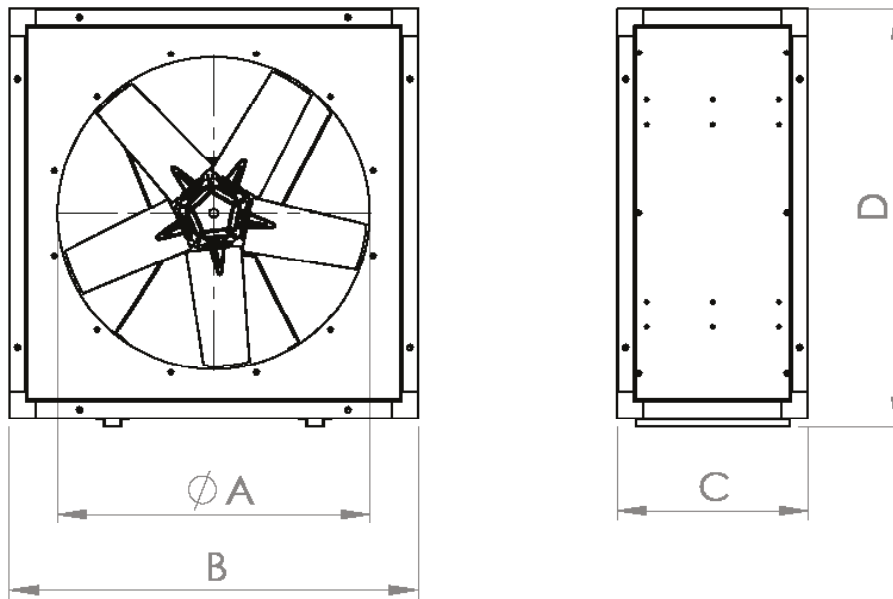

MODEL	A (mm)	B (mm)	C (mm)	D (mm)
NFDAX/BX 400	400	620	425	645
NFDAX/BX 450	450	670	425	695
NFDAX/BX 500	500	720	425	745
NFDAX/BX 560	560	780	425	805
NFDAX/BX 630	630	850	425	875
NFDAX/BX 710	710	930	425	955
NFDAX/BX 800	800	1020	425	1045
NFDAX/BX 900	900	1120	525	1145
NFDAX/BX 1000	1000	1220	525	1245
NFDAX/BX 1120	1120	1340	525	1365

# PERFORMANCE CURVES

NFDAX/BX 400-5-25

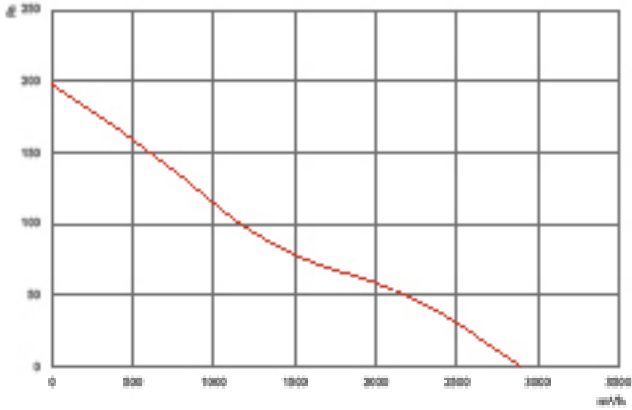

NFDAX/BX 450-5-25

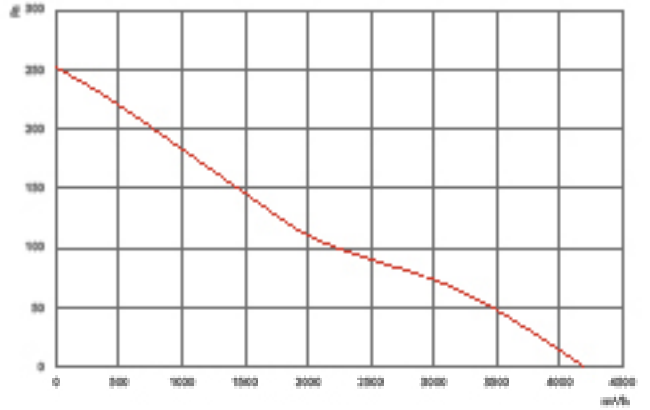

NFDAX/BX 500-5-25

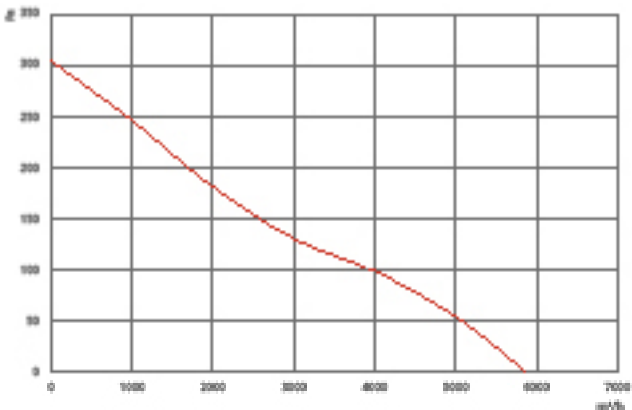

NFDAX/BX 560-5-25

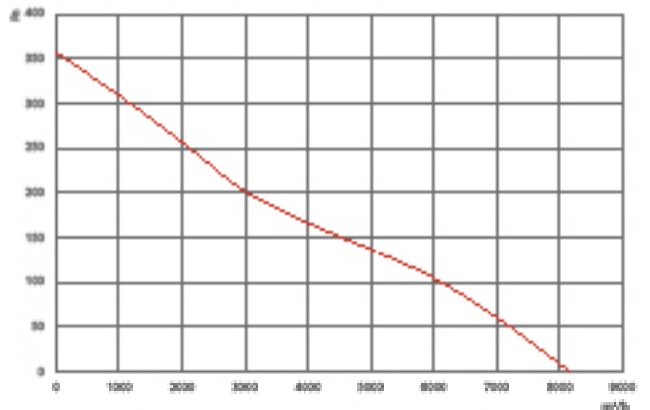

NFDAX/BX 630-5-30

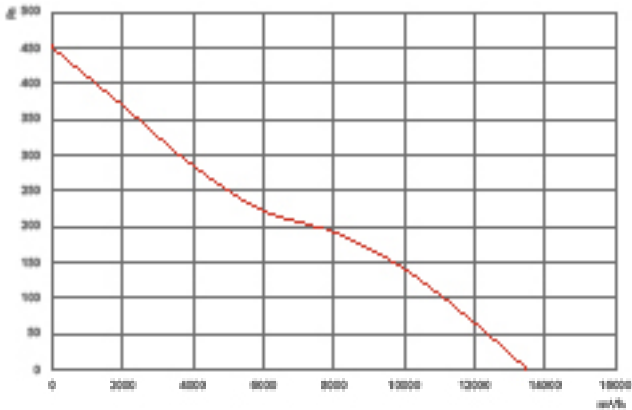

NFDAX/BX 710-5-30

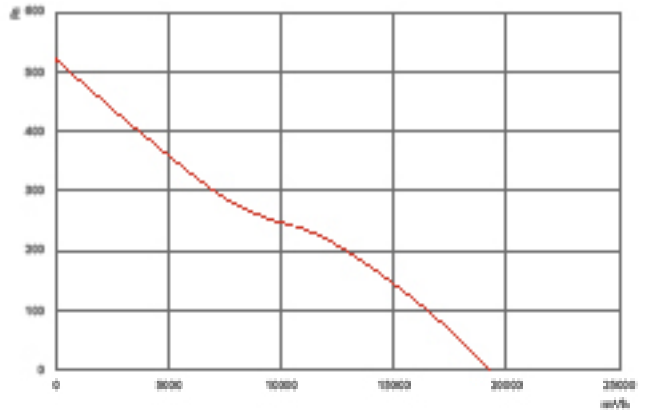

NFDAX/BX 800-5-30

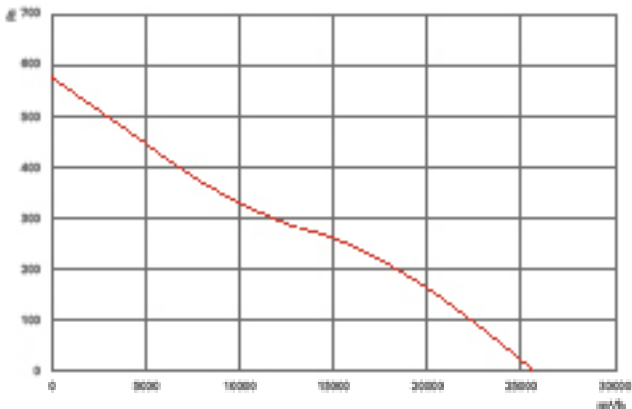

NFDAX/BX 800-5-35

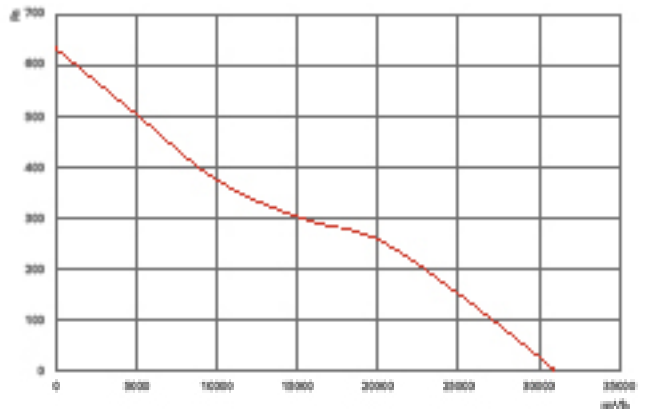

# PERFORMANCE CURVES

NFDAX/BX 900-5-35

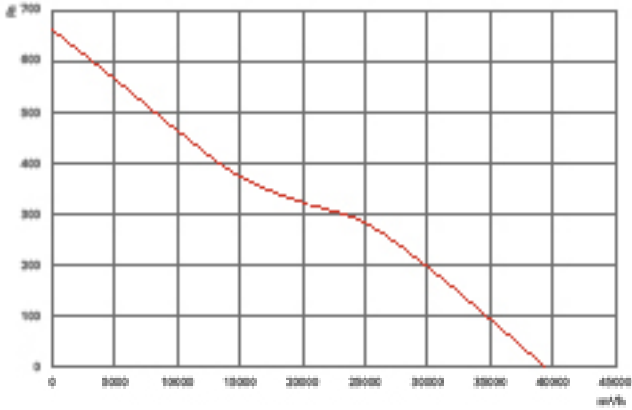

NFDAX/BX 900-5-40

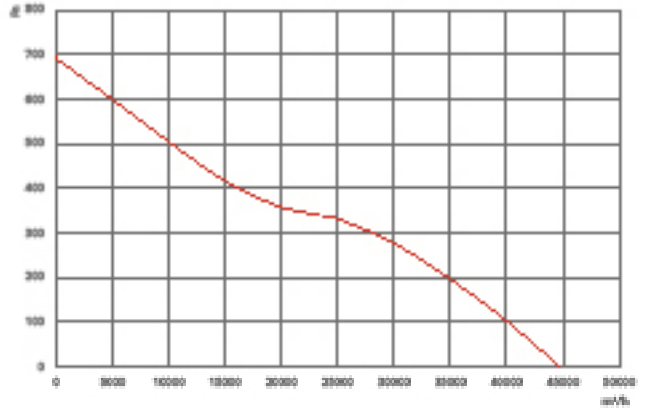

NFDAX/BX 1000-5-40

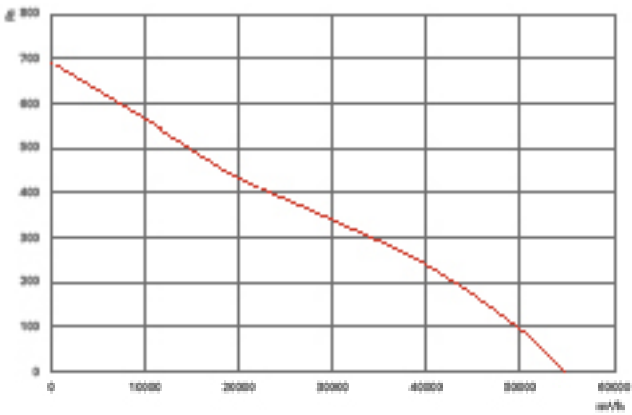

NFDAX/BX 900-8-40

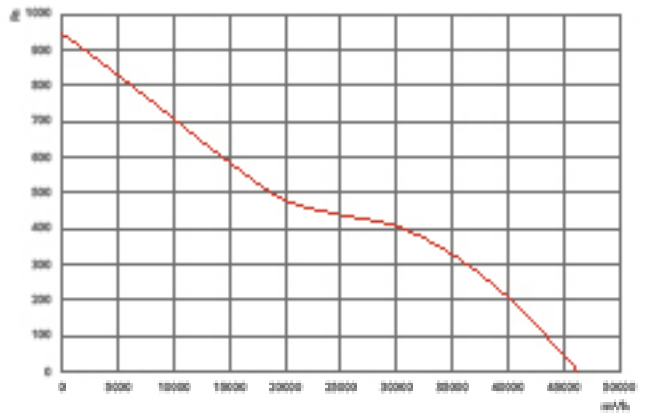

NFDAX/BX 1000-8-40

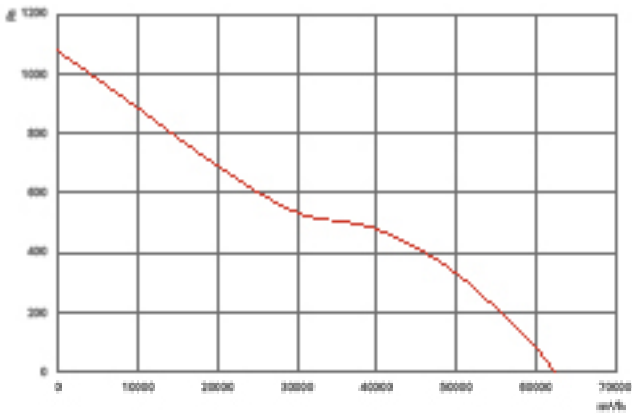

NFDAX/BX 1000-8-45

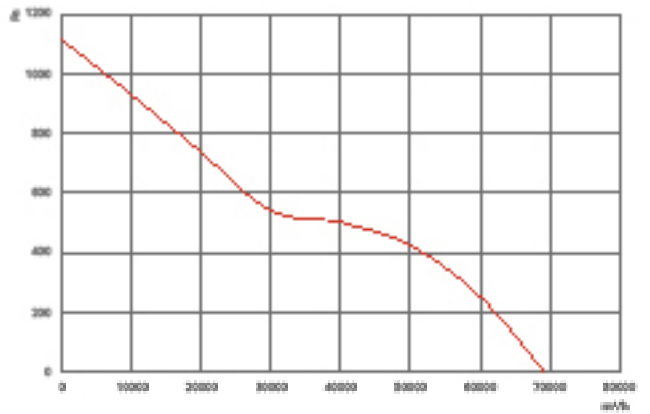

NFDAX/BX 1120-8-40

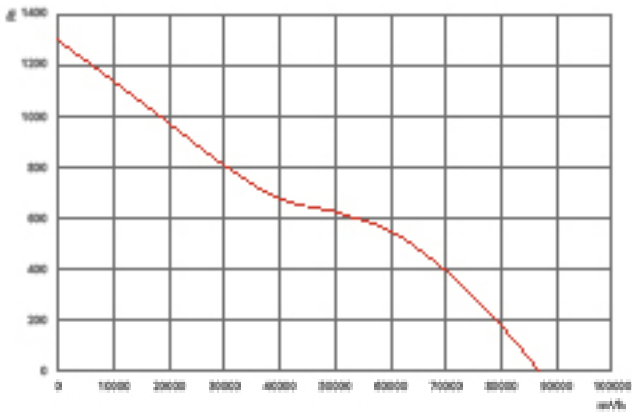

NFDAX/BX 1120-8-45

